

WE-2516J

Heavy Duty Center Bowl Wear Liner



Product Benefits

- Advanced Hollamax™ Material.
- Superior cold flow resistance.
- Designed for high mileage and heavy loads.
- Simple drop-in installation – no lubrication required.
- Prevents center plate and center bowl wear.



Amsted Rail

WE-2516J

Heavy Duty Center Bowl Wear Liner

Physical Properties

- Climate limitations:
-70°F to +180°F
- Surface load capabilities:
7420 psi @ 73.4° F
- Coefficient of friction:
.32
- Deflection:
@ 1000 psi = .001"
- Color: Blue

Application Notes

- Truck bolster bowl must be designed to accept vertical and horizontal bowl liner.
- Center plates and bolster bowls must be smooth; free of foreign material, weld splatter, and/or sharp edges.

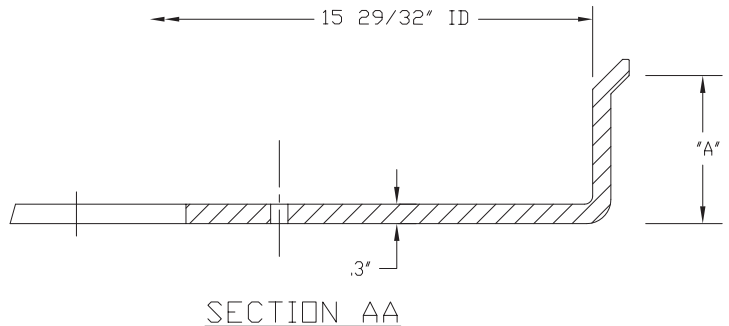
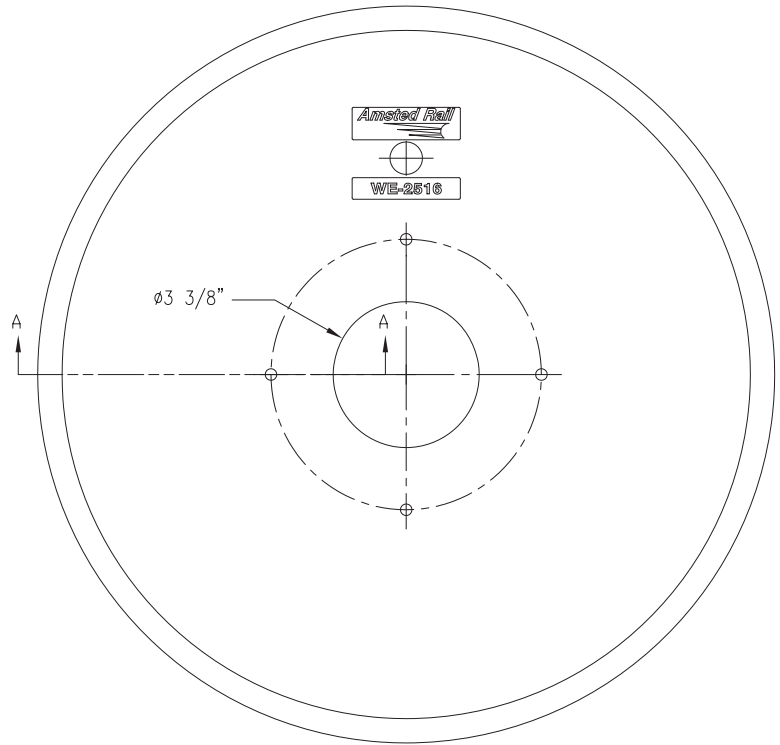

Part Number	DIM A
-------------	-------

WE-2516J	2"
----------	----

