

WE-5505

Brake Beam Guide Wear Eliminator

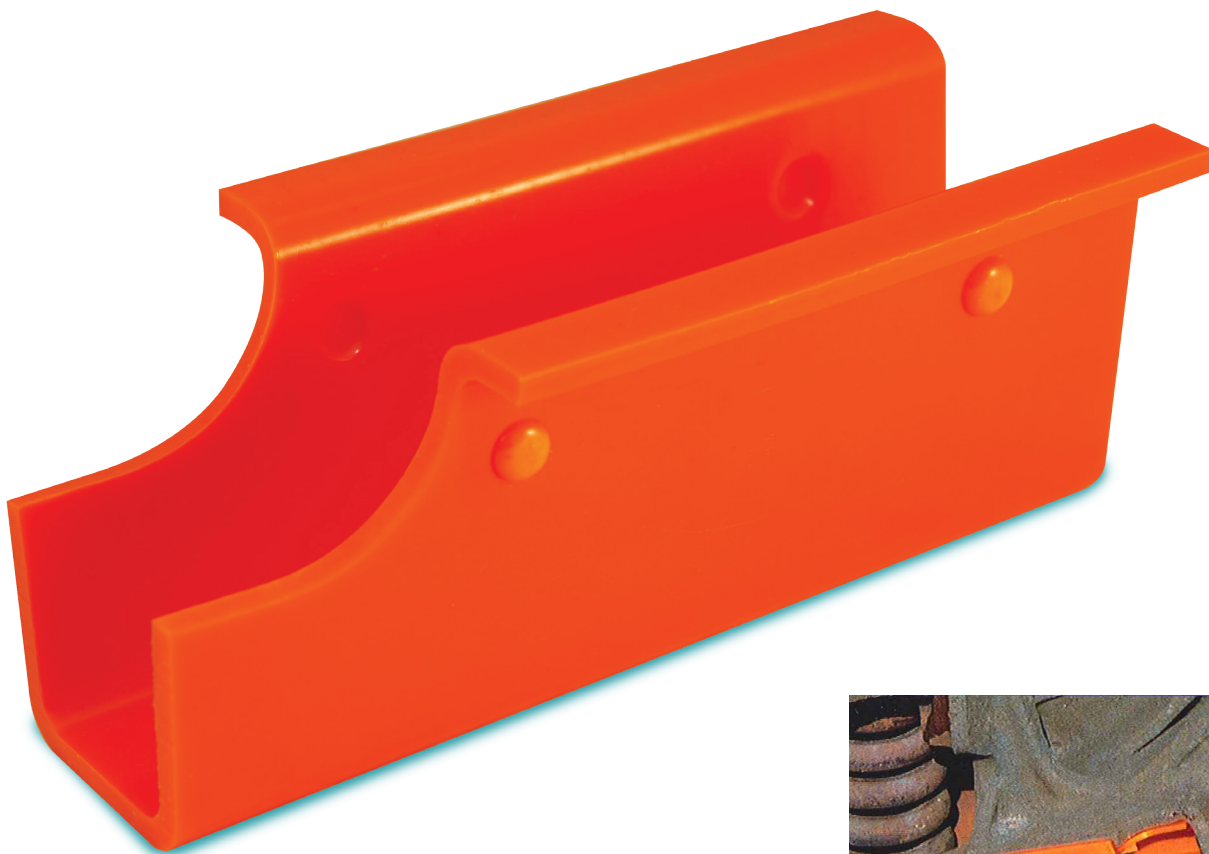

Product Benefits

- Reduces brake shoe consumption.
- Eliminates wear on brake beam guide, preventing brake beam droop and reduces wheel flange wear.
- Light weight.
- Our most economical brake beam guide wear eliminator.

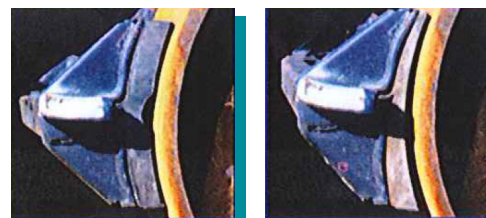

Brake beam droop causes shoe to contact wheel unevenly (right photo)

Amsted Rail

WE-5505

Brake Beam Guide Wear Eliminator

Physical Properties

- Climate limitations:
-70°F to +180°F
- Surface load capabilities:
1000 psi
- Coefficient of friction:
.15
- Deflection:
@ 1000 psi = .007"
- Color: orange

Application Notes

- Brake beam guide wear eliminators are most effective on new or restored brake beam guides.
- Brake beam guides must be smooth and free from sharp edges, weld splatter, and debris.
- Lubrication is not required.

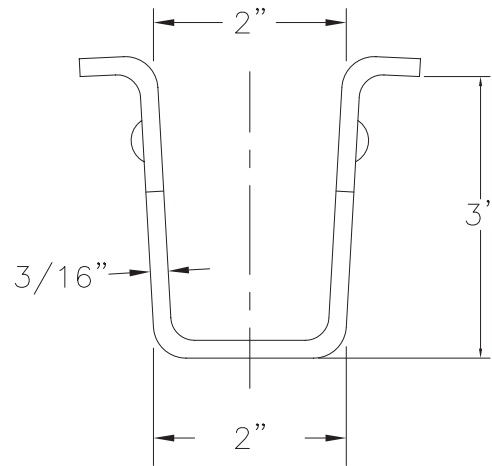
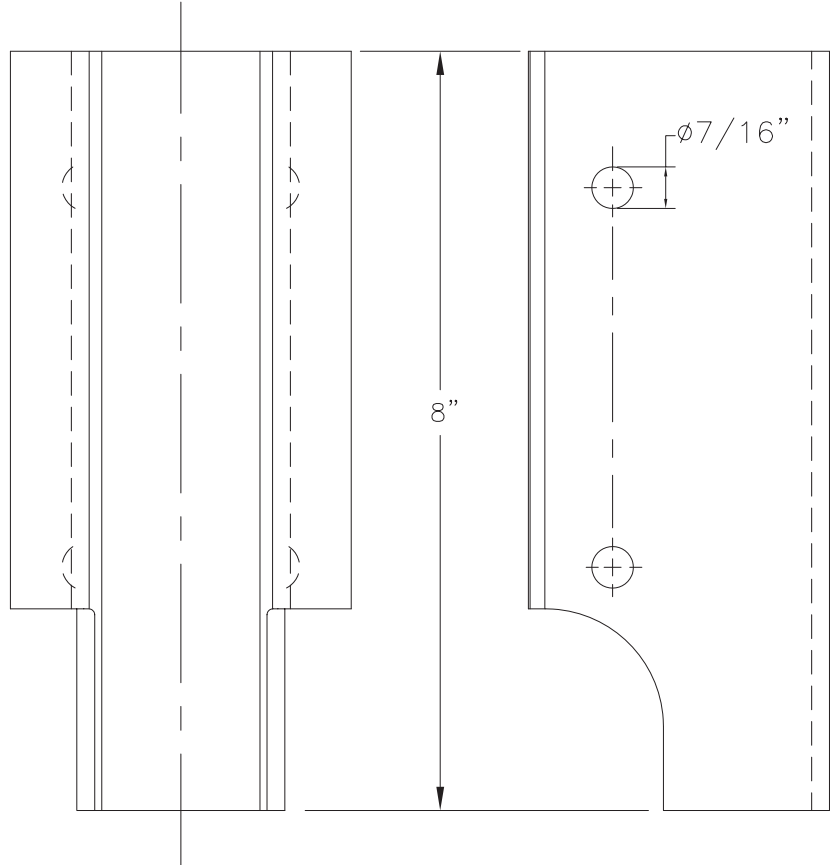

Amsted Rail