

## ENDURANCE® 325 FRICTION DRAFT GEAR

Protection, performance and durability  
in one lightweight package

- ▶ Lightweight, high-performance gear
- ▶ AAR M-901E unconditionally approved
- ▶ Offers 3-1/4" of travel in both the buff and draft direction
- ▶ Delivers 80 lb. weight savings over comparable 901E gears
- ▶ Fits a standard 24-5/8" draft gear pocket
- ▶ Utilizes the AAR-Standard yoke and follower
- ▶ Optimized housing design for longer life (lower stresses)



Endurance® 325 Typical Drop Hammer Performance Graph

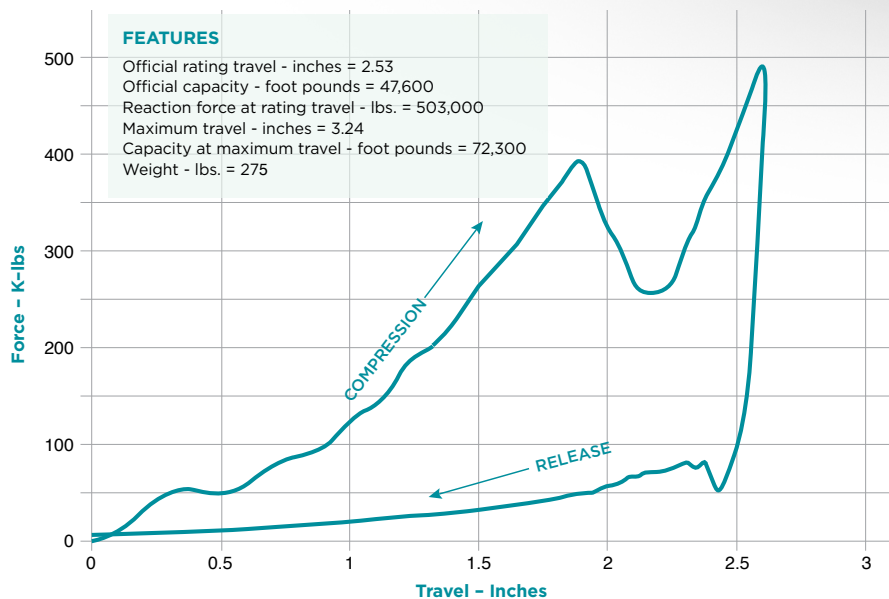

## Endurance® 325 Design Configurations

Right View

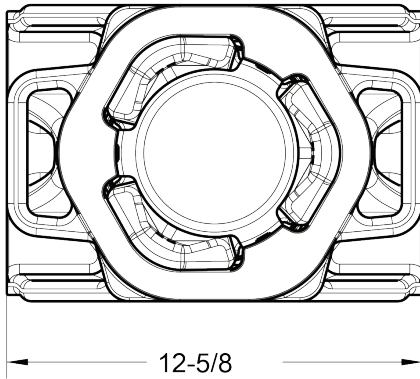

Bottom View

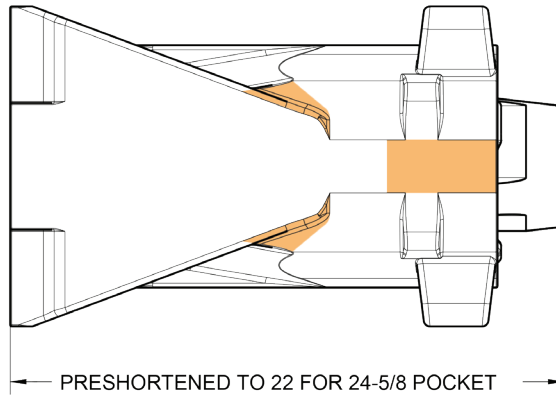

Side View

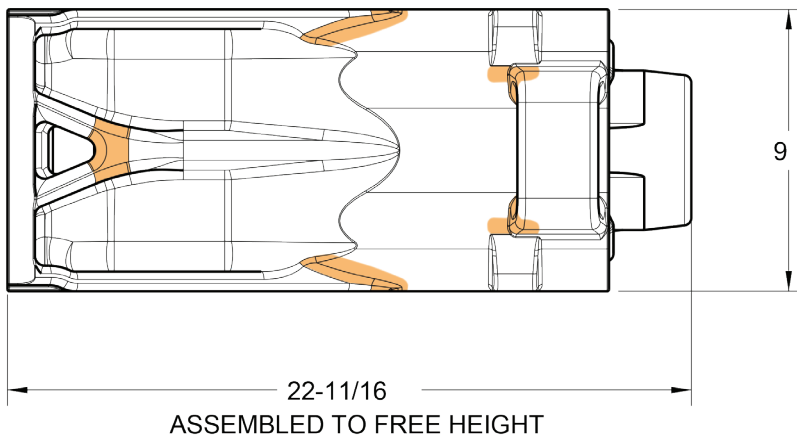

Areas of optimized housing design

## AMSTED RAIL, THE GLOBAL LEADER IN FULLY INTEGRATED FREIGHT CAR SYSTEMS FOR THE HEAVY HAUL RAIL MARKET.

Amsted Rail is the world's leading provider of undercarriage and end-of-car railcar components, with facilities spanning six continents. Through our state-of-the-art manufacturing processes, Amsted Rail has been redefining industry standards for innovation and technology since 1877, providing our customers worldwide with unmatched performance and reliability for the long haul.

To learn more, visit [www.amstedrail.com](http://www.amstedrail.com).

